

ICC-ES Evaluation Report

ESR-1236

Reissued August 2019

This report is subject to renewal August 2020.

www.icc-es.org | (800) 423-6587 | (562) 699-0543

A Subsidiary of the International Code Council®

DIVISION: 07 00 00—THERMAL AND MOISTURE PROTECTION

Section: 07 21 00—Thermal Insulation

REPORT HOLDER:

COVERTECH FABRICATING, INC.

EVALUATION SUBJECT:

rFOIL™ REFLECTIVE PLASTIC CORE INSULATION, AND rFOIL BIG-8™ REFLECTIVE PLASTIC CORE DUCT INSULATION

1.0 EVALUATION SCOPE

Compliance with the following codes:

- 2018, 2015, 2012 and 2009 *International Building Code*® (IBC)
- 2018, 2015, 2012 and 2009 *International Residential Code*® (IRC)
- 2018, 2015, 2012 and 2009 *International Mechanical Code*® (IMC)
- 2018, 2015, 2012 and 2009 *International Energy Conservation Code*® (IECC)
- 2013 *Abu Dhabi International Building Code* (ADIBC)†

†The ADIBC is based on the 2009 IBC. 2009 IBC code sections referenced in this report are the same sections in the ADIBC.

Properties evaluated:

- Thermal resistance
- Surface-burning characteristics
- Water vapor transmission

2.0 USES

rFOIL™ is recognized for use as insulation installed in floors and walls in buildings of any construction type. When installed in accordance with this report, rFOIL™ insulation provides thermal resistance values as noted in Section 4.1.2.

rFOIL Big-8™ is recognized for use as duct insulation for residential and commercial HVAC duct systems. When installed in accordance with this report, rFOIL Big-8™ insulation provides thermal resistance values as noted in Section 4.2.

3.0 DESCRIPTION

rFOIL™ reflective plastic core insulation is manufactured from two layers of polyethylene bubble material laminated on each side with a layer of flat polyethylene film with a

metalized surface film. rFOIL™ has a flame-spread index of 25 or less and a smoke-developed index of 450 or less when tested in accordance with ASTM E84 (UL 723). In this configuration, the water vapor permeance of the insulation is less than 1.0 perm when tested in accordance with ASTM E96.

rFOIL Big-8™ reflective plastic core duct insulation is manufactured from two layers of the rFOIL™ reflective plastic core insulation separated by 2-inch-wide strips of bubble pack insulation (see Figure 4 of this report). rFOIL Big-8™ has a flame-spread index of 25 or less and a smoke-developed index of 50 or less when tested in accordance with ASTM E84 (UL 723). In this configuration, the water vapor permeance of the insulation is less than 0.05 perm when tested in accordance with ASTM E96.

4.0 INSTALLATION

4.1 rFOIL™ Reflective Plastic Core Insulation Installation:

4.1.1 General: The insulation is stapled to wood studs, floor joists or furring with 5/16-inch-crown-width (7.9 mm) staples having a minimum leg length of 1/4 inch (6.35 mm), spaced at 6 inches (152 mm) on center. Seams or tears shall be patched with aluminum foil adhesive tape supplied by Covertech Fabricating, Inc.

The manufacturer's published installation instructions and this report must be strictly adhered to and a copy of these instructions must be available at all times on the jobsite during installation. The instructions within this report govern if there are any conflicts between the manufacturer's published instructions and this report.

4.1.2 Thermal Resistant Assemblies:

4.1.2.1 Wall Cavity Application: rFOIL™ insulation is placed on the inside of the stud cavity and stapled at the midpoint of the 3 1/2-inch (89 mm) side of 2-by-4 wood studs spaced at 16 inches (406 mm) on center. The insulation forms two 1 5/8-inch-deep (41.3 mm) air spaces within the cavity. The exterior surface is covered with 1/2-inch-thick (12.7 mm) plywood, complying with and attached in accordance with the applicable code. The interior surface is covered with minimum 1/2-inch-thick (12.7 mm) gypsum wallboard complying with ASTM C1396, attached in accordance with the applicable code. Inside surface-to-surface thermal resistance of the assembly is noted in Table 1 of this report. Thermal resistance of the insulated cavity described in this section is noted in Table 2 of this report. See Figure 1 of this report for an illustration of the assembly.

4.1.2.2 Crawl Space Application: The floor assembly consists of minimum of 2-by-8 wood floor joists spaced a

maximum of 24 inches (610 mm) on center, with a minimum of one layer of 3/4-inch-thick (19 mm) plywood on the upper surface, attached in accordance with the applicable code. The length of the insulation sheet is placed parallel to the floor joists. Inside surface-to-surface thermal resistance of the assembly is noted in Table 1 of this report. See Figure 2 of this report for an illustration of the assembly.

4.1.2.3 Furring Strip Block Wall Application: The block wall assembly consists of nominal 1-by-2 furring strips attached vertically at a maximum of 16 inches (406 mm) on center to minimum 8-inch-thick (203 mm) block wall. The insulation is installed parallel to the furring strips using fasteners noted in Section 4.1 of this report. A second layer of 1-by-2 furring strips is placed over the insulation and directly over the existing furring strips using 1 1/4-inch-long (38 mm) nails. Minimum 1/2-inch-thick (12.7 mm) gypsum wallboard complying with ASTM C1396 is attached over the furring strips in accordance with the applicable code to create two 3/4-inch (19 mm) air spaces. Inside surface-to-surface thermal resistance of the assembly is noted in Table 1 of this report. See Figure 3 of this report for an illustration of the assembly.

4.2 rFOIL Big-8™ Duct Insulation Application:

The rFOIL Big-8™ reflective plastic core duct insulation is installed using one of the following methods:

- a. To achieve a thermal resistance of R-8, 2-inch-wide spacer strips of rFOIL™ reflective plastic core duct insulation are wrapped around the duct to create spacers at 2-foot intervals. The Big-8 duct insulation is wrapped around the duct with the spacers creating an airspace between the duct and the insulation. All seams and joints are sealed using rFOIL Metalized Tape (see Figure 5 of this report).
- b. To achieve a thermal resistance of R-6, the Big-8 duct insulation is wrapped loosely around the duct without the spacers used in method (a). All seams and joints are sealed using rFOIL Metalized Tape (see Figure 6 of this report).

5.0 CONDITIONS OF USE

The rFOIL™ reflective plastic core insulation and Big-8 reflective plastic core duct insulation described in this report complies with, or is a suitable alternative to what is specified in, those codes listed in Section 1.0 of this report, subject to the condition that installation complies with this report, the manufacturer’s published installation instructions and the applicable code.

5.1 The rFOIL Big-8™ reflective plastic core duct insulation must be installed in accordance with the applicable requirements of Chapter 6 of the IMC.

5.2 Air ducts operating at temperatures exceeding 120°F (49°C) must be provided with sufficient thermal insulation to limit the exposed surface temperature to 120°F (49°C).

6.0 EVIDENCE SUBMITTED

Data and reports of tests in accordance with the ICC-ES Acceptance Criteria for Reflective Insulation (AC02), dated June 2011 (Editorially revised May 2018).

7.0 IDENTIFICATION

Each roll of product is labeled with the manufacturer’s name (Covertch Fabricating, Inc.); product name (rFOIL); surface-burning characteristics; thermal resistance (R-value) for rFOIL Big-8™; the wording “See ESR-1236 for the thermal resistance (R-value) of the assembly or assemblies”; the lot number; product dimensions; and the evaluation report number (ESR-1236).

7.1 The report holder’s contact information is the following:

COVERTECH FABRICATING, INC.
279 HUMBERLINE DRIVE
ETOBICOKE, ONTARIO M9W 5T6
CANADA
(416) 798-1340
www.rfoil.com
sales@covertchfab.com

TABLE 1—INSIDE SURFACE-TO-SURFACE THERMAL RESISTANCE (R-value) OF rFOIL INSULATION IN VARIOUS ASSEMBLIES¹

ASSEMBLY AND INSULATION	THERMAL RESISTANCE (R-VALUE) (hr. ft. ² °F/Btu)	REFER TO
Wall cavity—horizontal heat flow	6.36	Figure 1
Crawl space: Heat flow up	5.14	Figure 2
Heat flow down	9.05	Figure 2
Block wall—horizontal heat flow	7.67	Figure 3

For **SI**: 1 inch = 25.4 mm, 1 hr. ft.² °F/Btu = 0.176 m² K/W.

¹R-values shown include the contribution from the insulation, air space and studs (or joists) only.

TABLE 2—THERMAL RESISTANCE (R-VALUE) (hr. ft.² °F/Btu) OF CAVITIES INSULATED WITH rFOIL^{1,2}

HEAT FLOW UP	HEAT FLOW DOWN	HORIZONTAL HEAT FLOW
5.30	10.57	6.83

For **SI**: 1 inch = 25.4 mm, 1 hr. ft.² °F/Btu = 0.176 m² K/W.

¹Framing is 2-by-4 wood studs spaced 16 inches on center. Insulation is installed as described in Section 4.2.

²R-values shown include the contribution from the insulation and air space only.

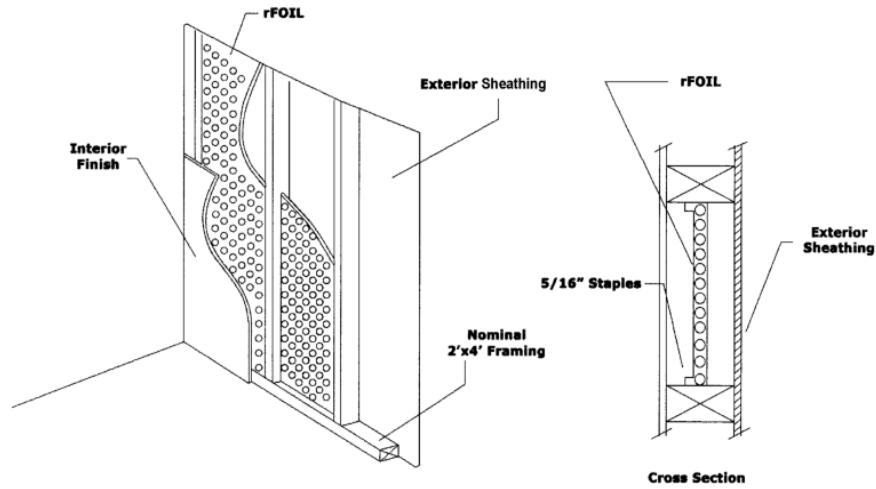

FIGURE 1—WALL CAVITY APPLICATION
SI: 1 inch = 25.4 mm

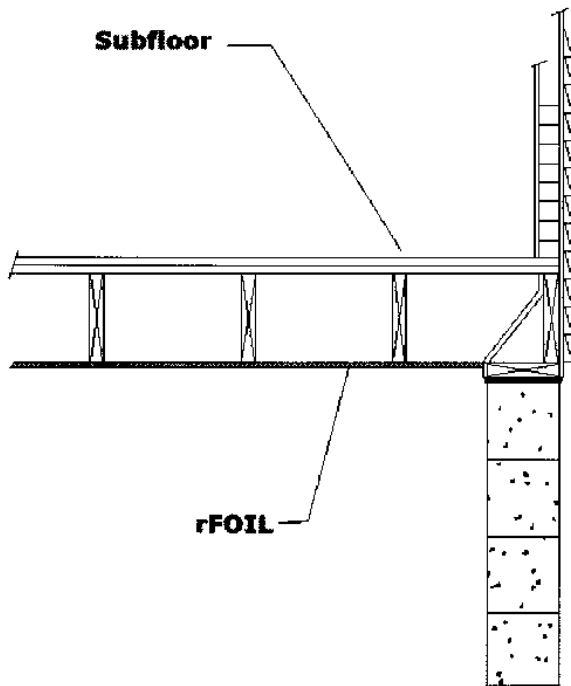

FIGURE 2—CRAWL SPACE APPLICATION

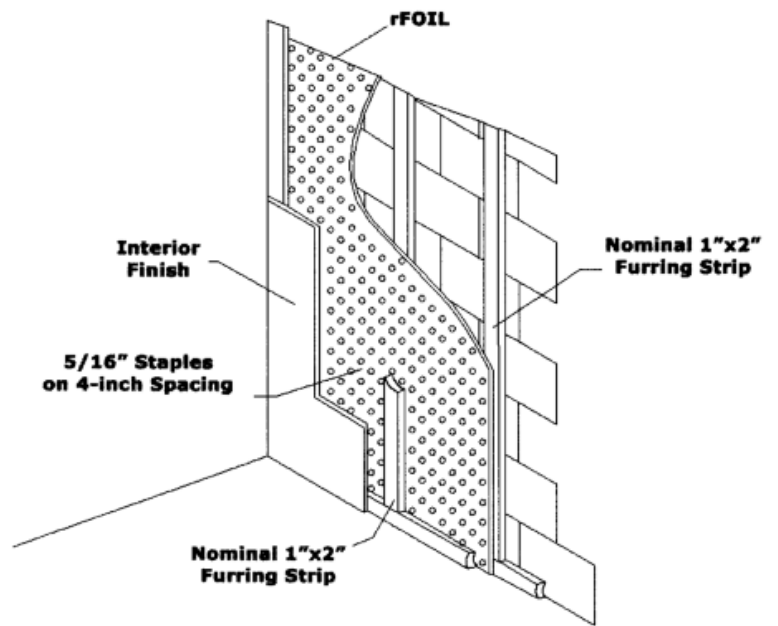

FIGURE 3—DOUBLE FURRED BLOCK WALL APPLICATION
SI: 1 inch = 25.4 mm

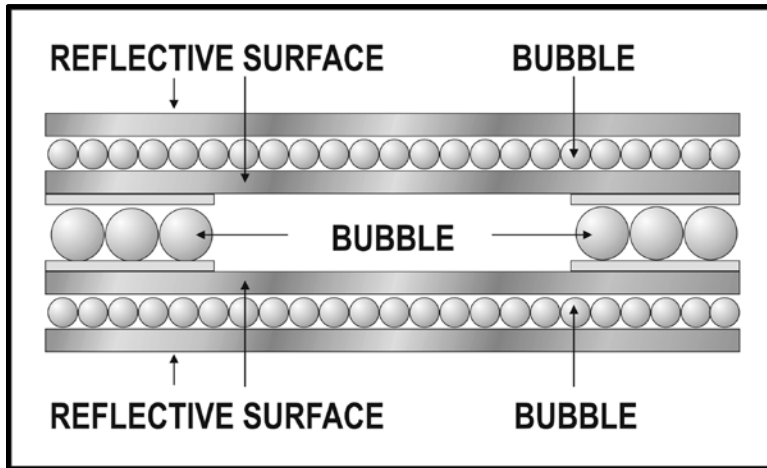
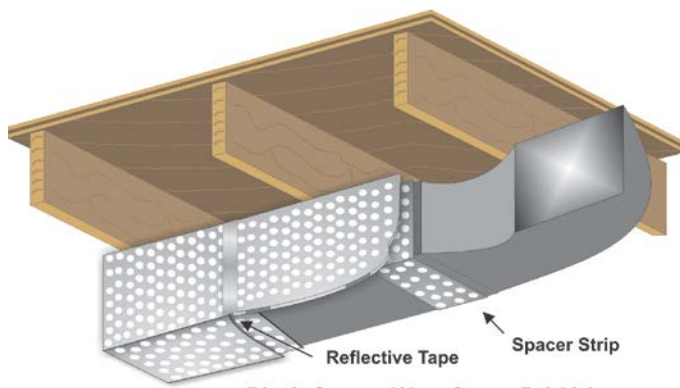
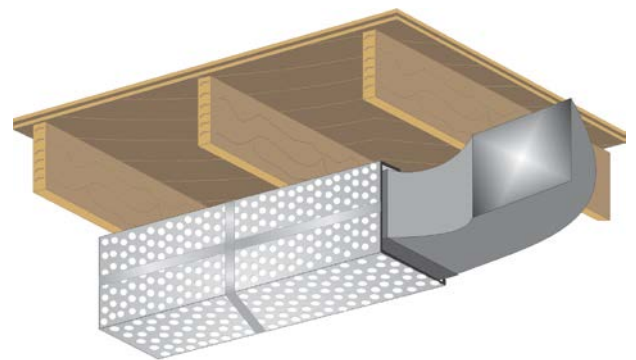

FIGURE 4—BIG-8 SPEC DRAWING



*Big-8 Spacer Wrap for an R-8 Value
(With Spacer Strips)*

FIGURE 5



*Big-8 Direct Wrap for an R-6 Value
(Without Spacer Strips)*

FIGURE 6